



# Installation Instructions

## Stuppy SWAMP THING®

(For 4" Wet Pad System Only)

### Service & Installation

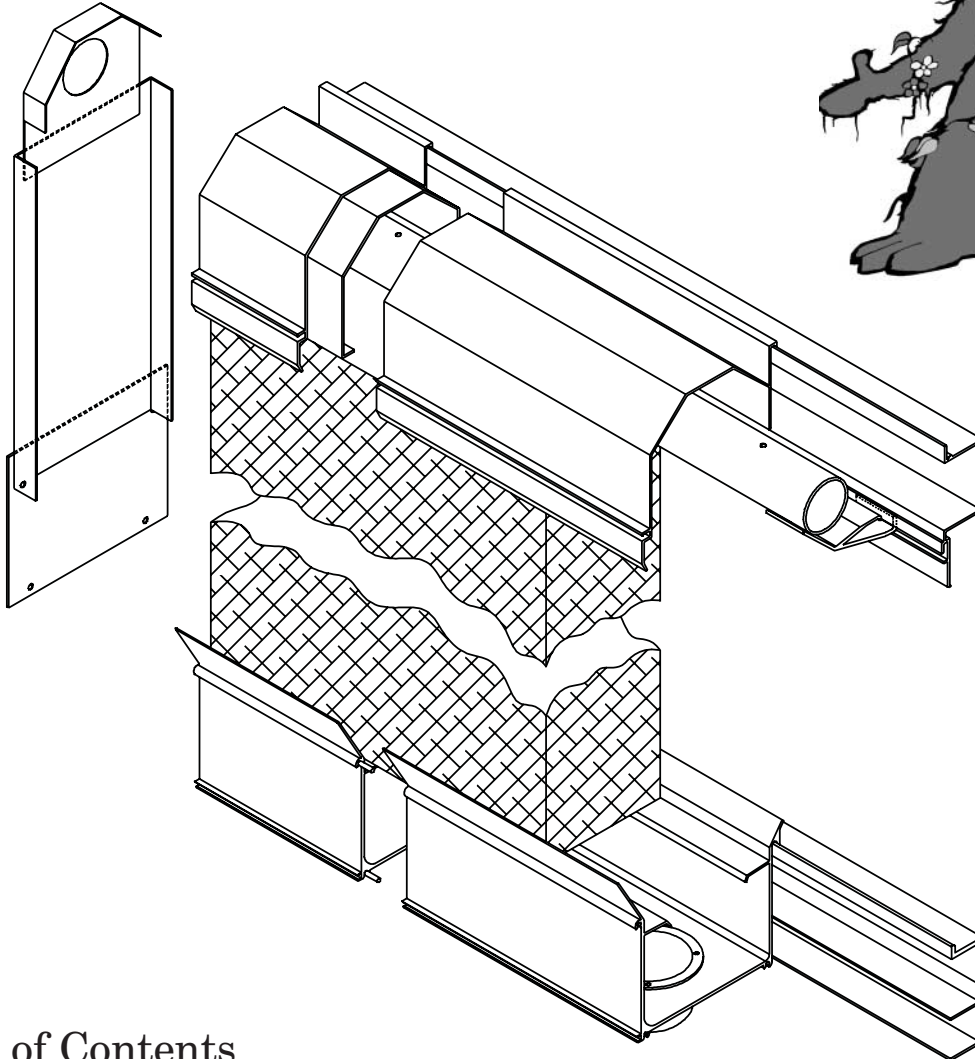

### Table of Contents

- I. Parts List
- II. Required Tools & Materials
- III. Building Preparation
- IV. System Installation
- V. System Start-up and Testing
- VI. System Maintenance
- VII. Pad Care

#### NOTES:

- 1) Review installation instructions and parts list before beginning installation.
  - 2) Determine installation location (refer to building plans).
  - 3) Determine size and placement height of system (see sales quote).
- Typical placement of a system is at the desired growing height.*

# Installation Instructions



## SWAMP THING® (continued)

### I. Parts List

#### NOTES:

System may be comprised of combinations of 6', and 10' sections to achieve your ordered system length.

System will be packaged in 6', and 10' boxes which includes the lineal usage parts and additional completer packages will be boxed separately to include parts used at the ends of the system.

#### Parts Drawing

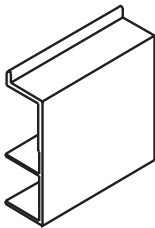

P4632 (6')  
P4633 (10')  
Pad System  
Bottom Stringer

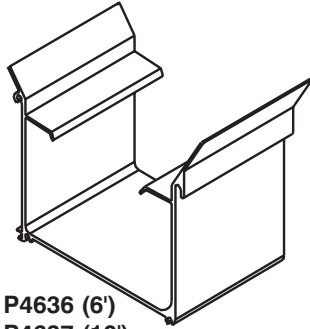

P4636 (6')  
P4637 (10')  
Pad System  
Return Gutter  
w/o drilling

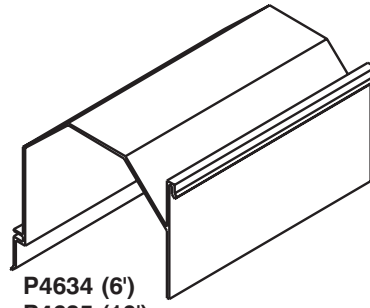

P4634 (6')  
P4635 (10')  
Pad System  
Supply Cap

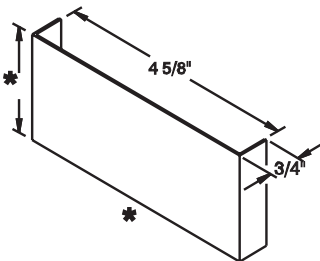

P3520 (24"), P3521 (36")  
P3522 (48"), P3523 (60")  
Pad System End Panel

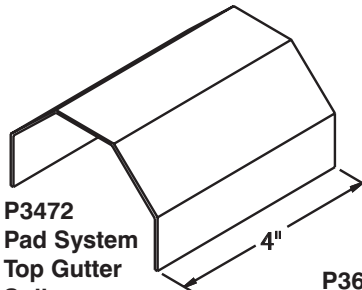

P3472  
Pad System  
Top Gutter  
Splice

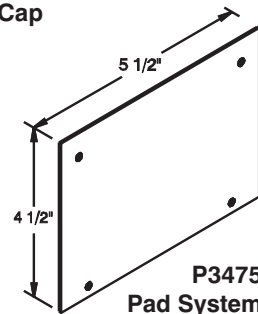

P3475  
Pad System  
Gutter End Cap

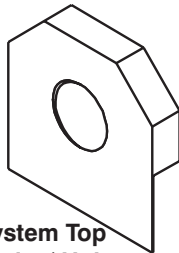

P3474  
Pad System Top  
Cap End w/ Hole

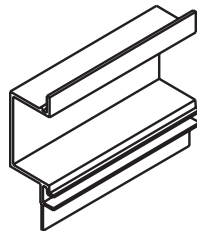

P4630 (6')  
P4631 (10')  
Pad System  
Top Stringer

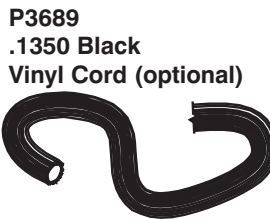

P3689  
.1350 Black  
Vinyl Cord (optional)



3320  
Alum.  
Downspout  
x 2-3/8"



10691  
1/4 x 3/4 Alum.  
Hex Head Bolt



P-1178  
1/8 Pop Rivet

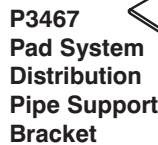

P3467  
Pad System  
Distribution  
Pipe Support  
Bracket



10692  
Locknut  
1/4 Alum.

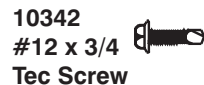

10342  
#12 x 3/4  
Tec Screw

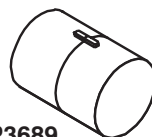

P3689  
1-1/4" Coupler  
for PVC

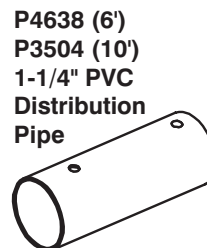

P4638 (6')  
P3504 (10')  
1-1/4" PVC  
Distribution  
Pipe



P3690 (50')  
Alum./Butyl.  
Tape x 2"

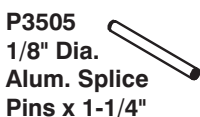

P3505  
1/8" Dia.  
Alum. Splice  
Pins x 1-1/4"

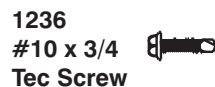

1236  
#10 x 3/4  
Tec Screw

Service & Installation



(800) 733-5025  
FAX (800) 423-1512



# Installation Instructions

## SWAMP THING® (continued)

### II. Required Tools & Materials

#### A. Tools

- Handsaw
- Pliers or vise grips
- Hammer
- Drill
- 1/8" and 1/4" drill bits
- 1/4" and 5/16" hex chuck
- Pipe wrenches, 2 each
- Chalk Line
- Level

#### B. Materials

- Rivet gun
- Building string
- Caulk gun
- 2-3/8" hole saw (supplied)
- PVC Cement
- PVC Cleaner
- Block wood, eg 2x4x6
- Tubes sealant (supplied)

### III. Building Preparation

#### A. Location of Pad System

Evaporative Cooling Pads should be placed away from fans (opposite) so that moisture laden air may flow throughout the greenhouse without turbulence.

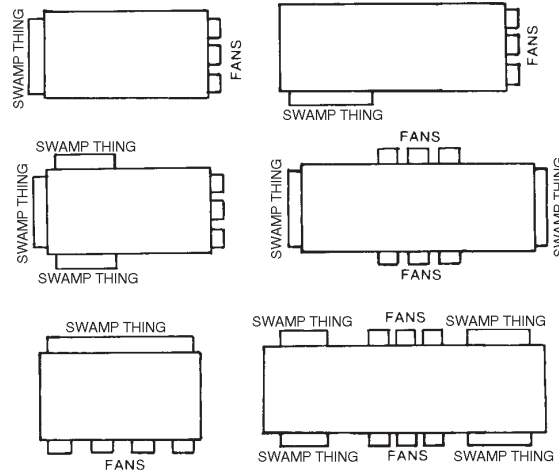

#### B. Framed Opening and Dimensions

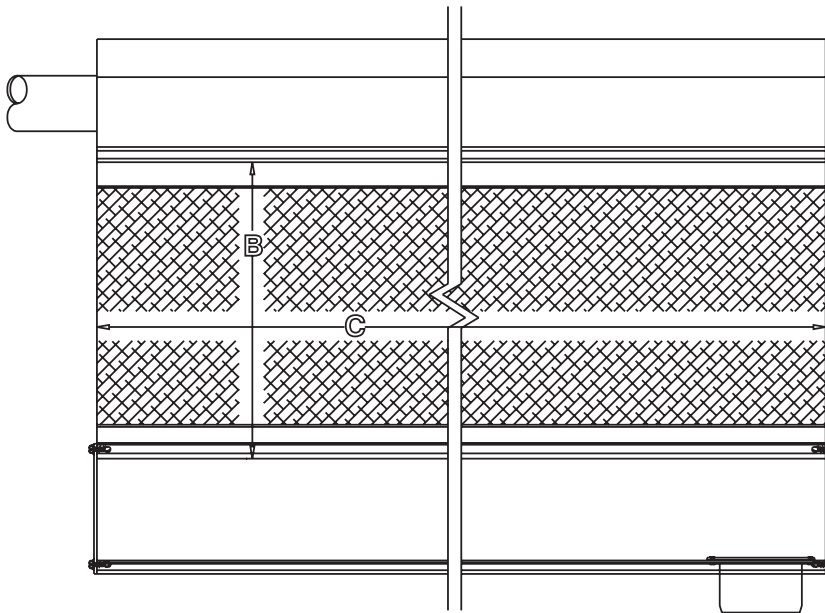

- A = Pad Height
- B = Vertical R.O. (Pad Height Plus 1/2")
- C = Pad System Length
- D = Overall System Height (Pad Height Plus 6-1/2")
- E = 8" Minimum for Return Plumbing to Sump.  
Must Be Increased If Sump Tank Is Located Above Grade.

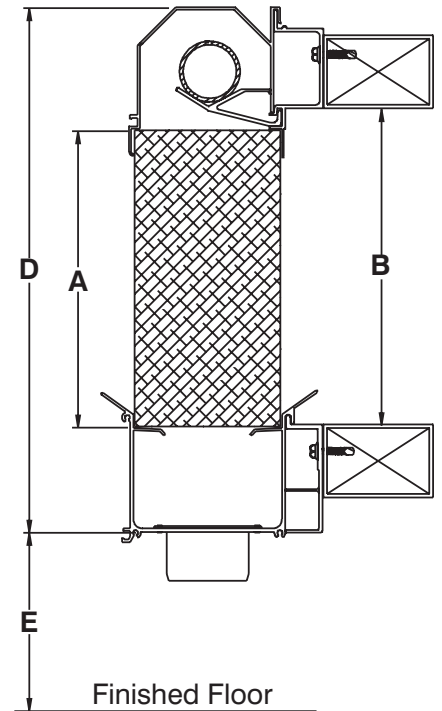

See Pages 242 and 243 for Sump and Water Supply Information.

# Installation

## SWAMP THING® (continued)



### C. Surface Requirements

1. Pad system can mount to any flat wall surface capable of supporting approximately 2.75 lbs per square foot of proposed pad area. (This weight is primarily carried by the bottom stringer/gutter section.)

If using stud-wall construction, horizontal blocking (front to back) will be required between studs to prevent air leakage. Blocking will be required behind both top and bottom stringers with a rough opening (R.O.) equal to dimension B (shown above).

2. Take steps during construction to insure that attachment surface is plumb and does not wave in and out as you look down the wall section.

### D. Sloping Requirements - Sump Location and Sizing

System operation requires the system to slope towards a sump collection site. Sump location depends upon total system length.

1. Sloping Requirements/System Length. The minimum recommended slope for the system is 1/4" per 10 feet of length. At 1/4" per 10 foot length, the maximum length of the system should be 60 feet. Systems greater than 60 feet and less than 120 feet would require the system to slope toward the center.

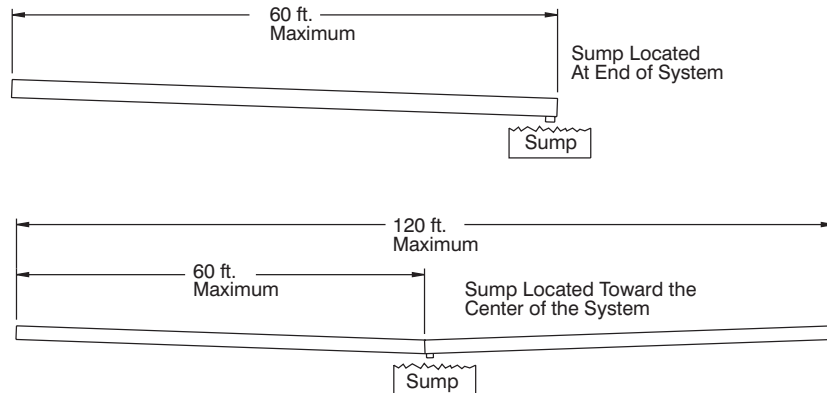

2. Sump Tank. Provide a tank with a capacity of 3/4 gallon per square foot of proposed pad area. The tank should be provided with an opaque cover to prevent algae growth. Depending upon pump type, the cover may be required to support a 50 pound pump. The sump should be set before installation of the pad system.

**Increased Lengths/Slope. Increasing the slope of the system will allow for greater system lengths as shown below:**

System Slope per 10 Feet	Maximum Recommended Length
1/4"	60 feet
3/8"	75 feet
1/2"	85 feet

## IV. System Installation

### A. Mount Bottom Stringers

1. Stringer should be fastened to prepared, flush wall section and sloped at 1/4" (minimum) per 10 foot length.

a. Attaching to metal framing. Use #12 x 3/4 tec screws, approximately 12" O.C.

b. Attaching to wood framing. Pre-drill 1/8" holes in stringer and use two (2) #10 (minimum) wood tites or screws per stud (or 12" O.C. if attaching to horizontal wood girt).

2. Additional blocking support of bottom stringers. Blocks may be added at 5' O.C. spacing where stringer is positioned too high or low on the primary girt member.

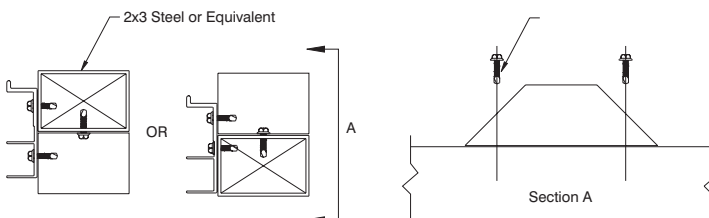

**B. Mount Top Stringers.** Mount top stringers parallel to bottom stringers at the distance of the pad height plus 1/2 inch. Follow fastening requirements for top stringer.

*Helpful Hint: Cut two (2) pieces of wood to pad height plus 1/2" to use as spacers.*

### C. Install Return Gutter Sections.

1. Locating and installing downspout.

a. Lay out return gutter sections and determine location of downspout at the sump.

b. Using supplied hole saw (item #33201) drill a 2-3/8" (diameter) hole, using drill guide to center, through the bottom of the return gutter section.

c. Installing downspout. Use supplied downspout as template to pre-drill 1/8" (diameter) holes through bottom of gutter.

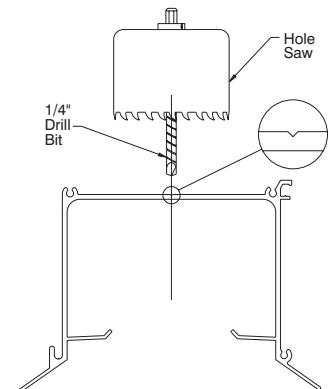



# Installation

## SWAMP THING® (continued)

# Service & Installation

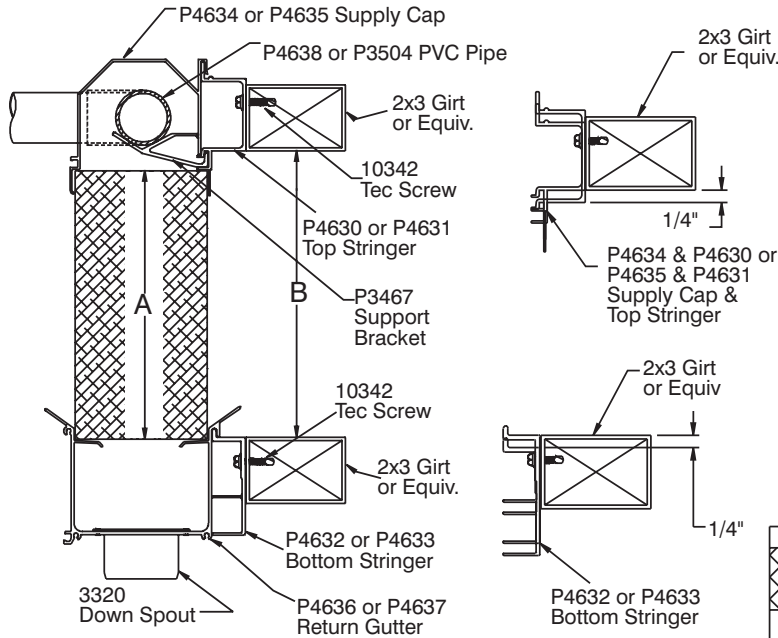

A	B	Acme	Acme
Pad Height	Pad Height + 1/2	Shutter	Model #
24	24-1/2	23 X23	WAC2626MT
36	36-1/2	37 X37	WAC4040MT
48	48-1/2	42 X42	WAC4040MT
60	60-1/2	60 X59	WAC6362MT

### STRINGER OFFSET DETAIL

NOTE: Pad System Return Gutter Stringer and Pad System Supply Cap Must Run Parallel to Each Other and Slope at the Rate of 1/4" (Minimum) Every 10 Feet.

See Page 4 for Sump Information.

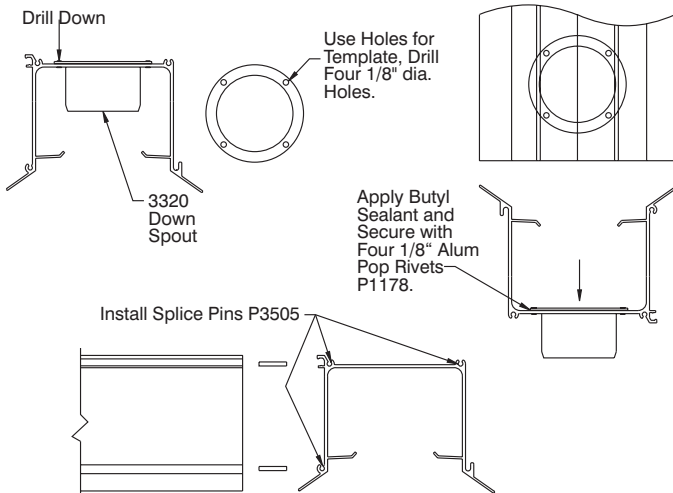
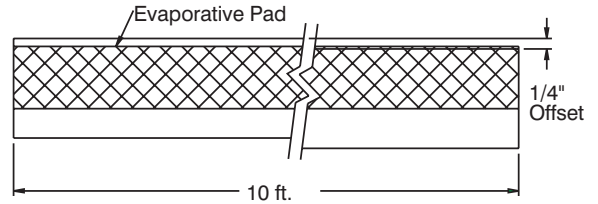
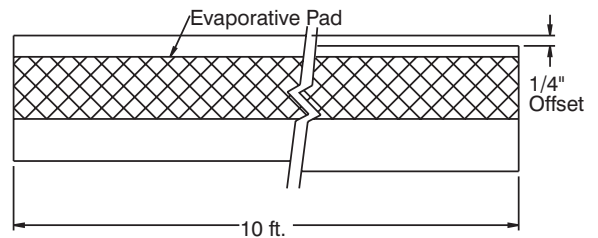
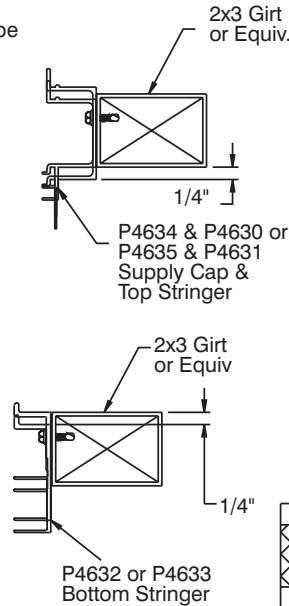

b. Using a pair of pliers, vise grips, or hammer and chisel, squeeze the material of the gutter around the pins to keep them secured.

c. Clean inside surfaces of abutting ends of gutter with a solvent to remove any oils or dirt (approximately 2 inches in from the ends).

d. Slide first gutter section down onto the bottom stringer. Positioned so that the ends of the extrusions are flush to one another.

e. Apply a small bead of butyl sealant to end face of first gutter section.

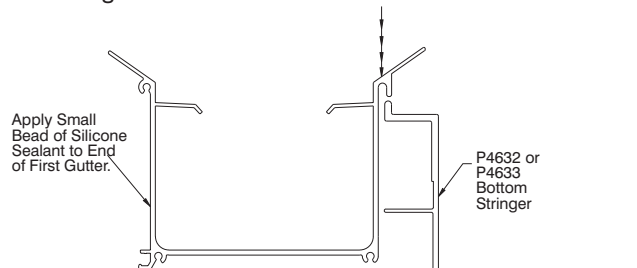

2. Splicing of gutters. Gutter sections are held together using aluminum splice pins and are sealed with a 2" wide piece of aluminum-butyl splice tape.

a. Insert splice pins, three (3) each, into the end of the first gutter that will butt-up with the second gutter section. Insert to approximately half of the pins length.

# Installation

## SWAMP THING® (continued)



# Service & Installation

- f. Install second gutter section (with pins installed in the far end) down onto bottom stringer. Slide the two extrusions together, line up the splicing pins with the holes in the second gutter section. Use a block of wood and a hammer to help drive the gutter sections together.
  - g. Cut three (3) pieces of aluminum-butyl splice tape. Two (2) at 2-1/2" long and one (1) at 9-1/4" long. Install 9-1/4" length of tape first. Center tape over joint and firmly press tape into place. Continue with the 2-1/2" lengths as shown.
  - h. Repeat applicable steps a. through g. for the remaining gutter sections.
3. Installing return gutter endcap.

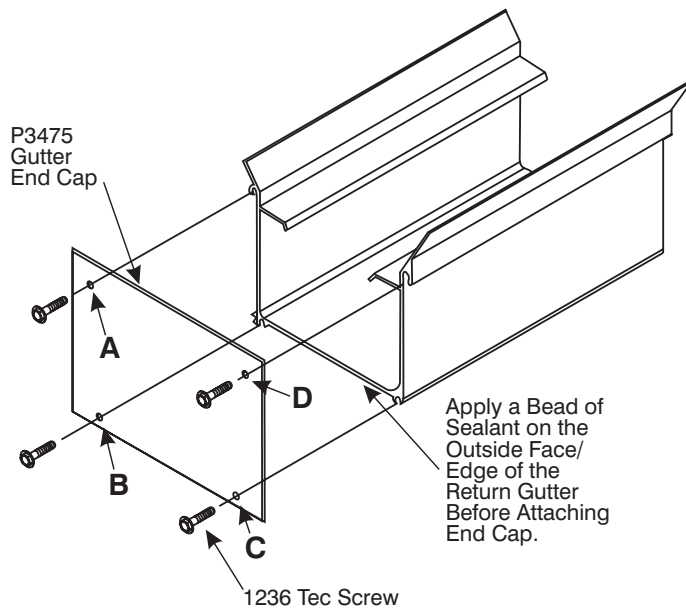
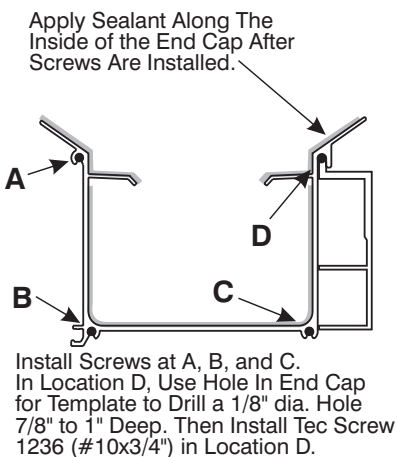
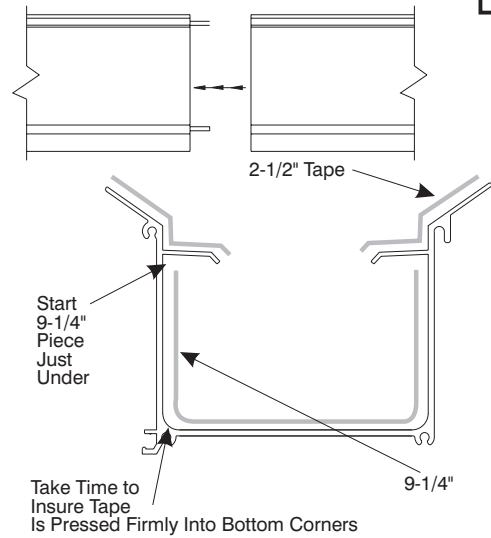

### D. Installation of Distribution Pipe

1. Install pipe support clips approximately 48" O.C. No fasteners are required. Parts are rotated into place.

#### 2. Sump connection.

- a. Sump located at center of system. Place section of pipe near center of system with distribution holes pointing directly up and connect the tee to the pipe; making sure the small hole in the tee is also pointing up.

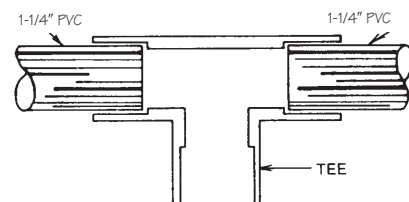
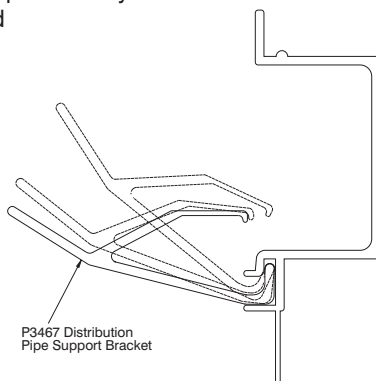

NOTE: It is important that all holes point directly up for uniform water distribution across the pads.

- b. Sump located at end of system. Place section of pipe at the end of the system with distribution holes pointing directly up. Begin distribution pipe 1-1/2 inches beyond the edge of the system.

NOTE: It is important that all holes point directly up for uniform water distribution across the pads.

3. Install remaining pipe using the supplied couplings (holes pointing directly up). Connections should be tightly pushed together, DO NOT GLUE TOGETHER. Extend supply line past end of system approximately 1-1/2 inches, cut pipe off square and remove any burrs.

4. Place supply cap endcap with holes on each end of the distribution pipe, facing the legs toward the center of the system.

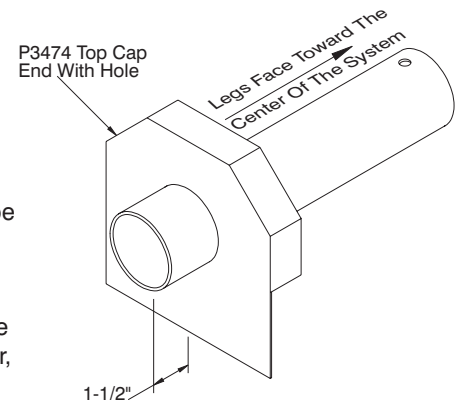

(800) 733-5025  
FAX (800) 423-1512



# Installation

## SWAMP THING® (continued)

### Service & Installation

#### E. Plumbing Setup

**Supply plumbing setup for sump located toward center of system.**

All PVC connections shall be cemented, except for internal couplings and tee connection on the 1-1/4" distribution pipe.

Be careful not to get cement on threads of the female adapters.

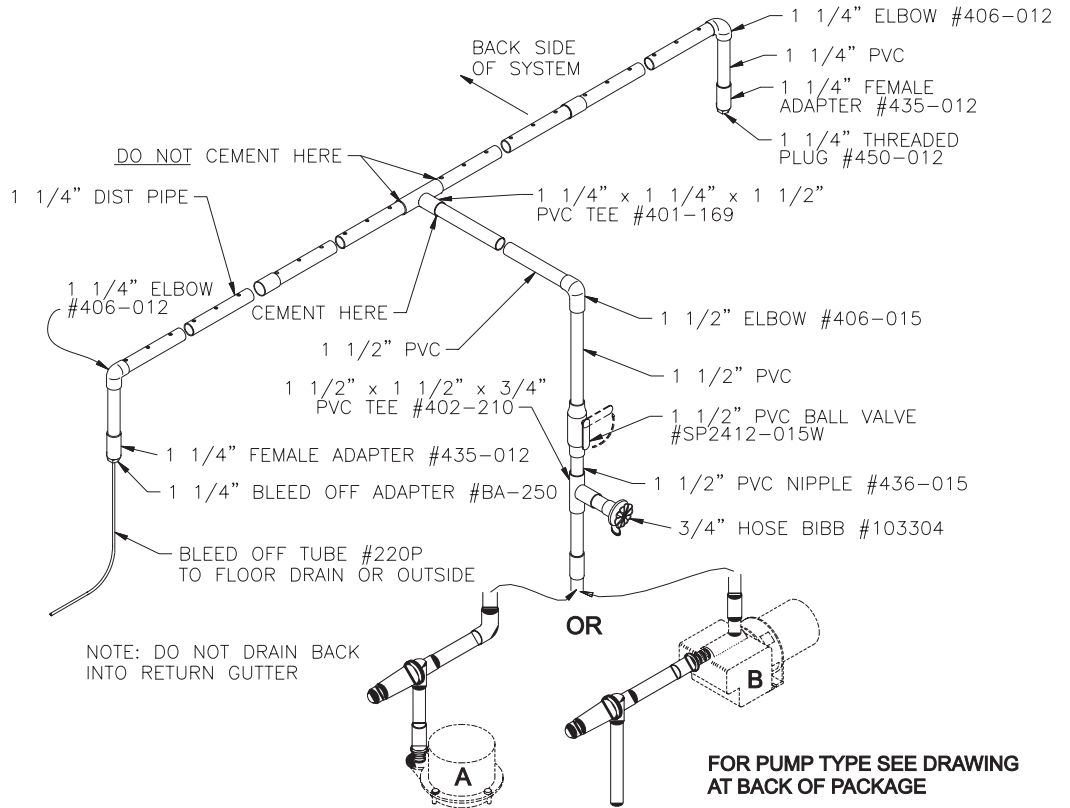

FOR PUMP TYPE SEE DRAWING AT BACK OF PACKAGE

**Supply plumbing setup for sump located at the end of the system.**

All PVC connections shall be cemented, except for internal couplings and tee connection on the 1-1/4" distribution pipe.

Be careful not to get cement on threads of the female adapters.

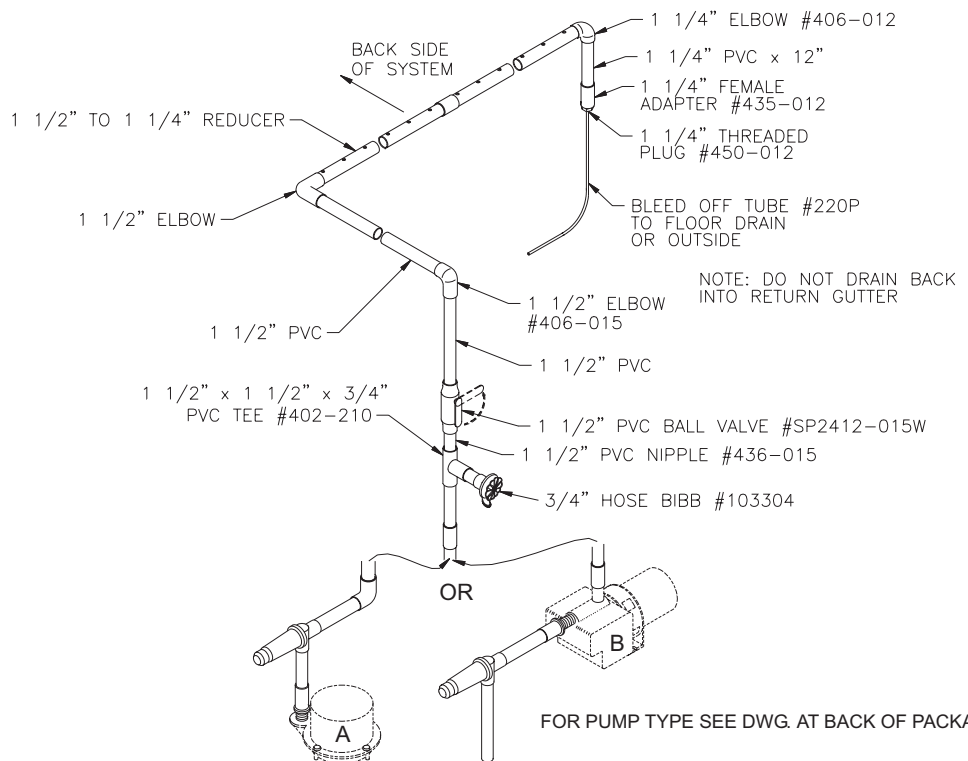

FOR PUMP TYPE SEE DWG. AT BACK OF PACKAGE

See the Following Page for Additional Pump Information.

# Installation

## SWAMP THING® (continued)



# Service & Installation

#20  
Submersible  
Pump

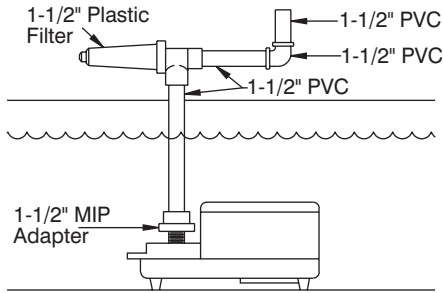

#30 Pump

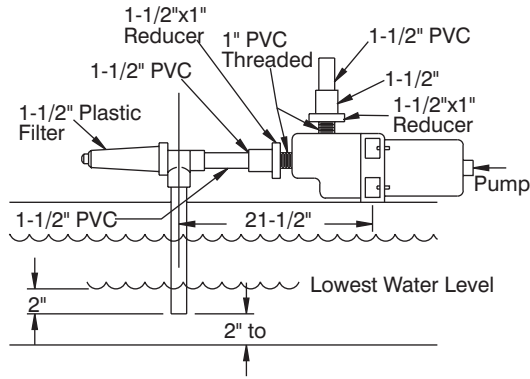

#60 & 90 Pump

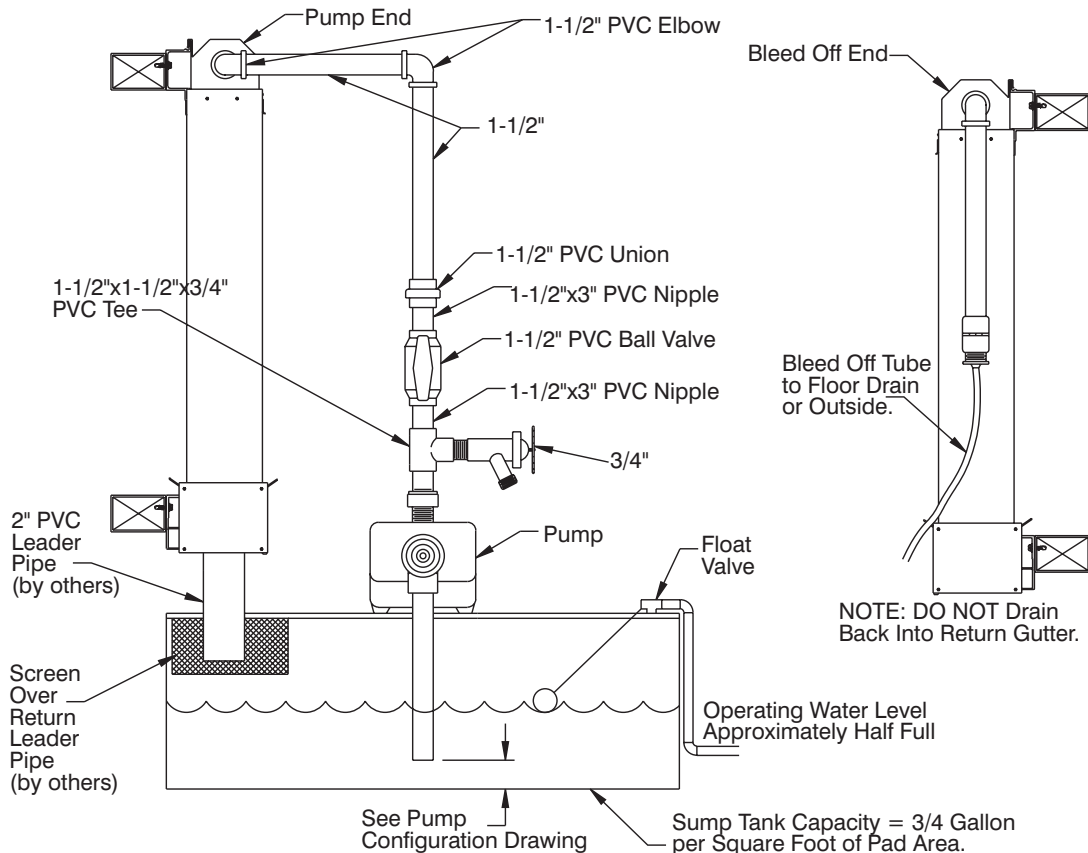
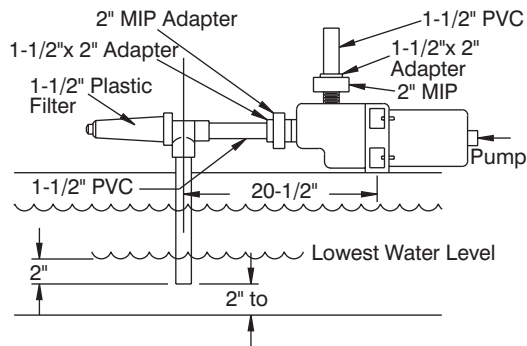

(800) 733-5025  
FAX (800) 423-1512



# Installation

## SWAMP THING® (continued)

### Service & Installation

#### F. Pad Installation

1. Beginning at one end of the system, install the 1 foot sections of pad into the return gutter. Press pads down to seat on the pad support surface. Slide the first pad tightly against the return gutter end cap. Each additional pad sections should be firmly pressed against the previous pad to eliminate any gaps between them.

2. For pad systems 60" or taller, or if comprised of vertically stacked sections of pad, it will be necessary to use "Tall Pad Supports". The Tall Pad Supports are installed between every other pad. Position supports centered on the height and depth of the pads. The supports are simply pressed between the pad section.

3. Continue installation until the end of the system is reached. The last pad may require trimming to fit easily in the remaining space. DO NOT FORCE PADS into a space that is smaller than the pad. Trimming of the pads is easily done with a hand saw.

**G. Start-up and Testing.** It is important to follow start-up and Testing Procedures at this time (Section V).

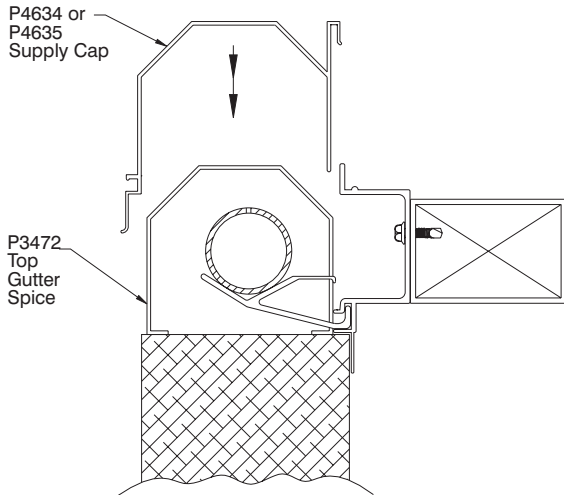
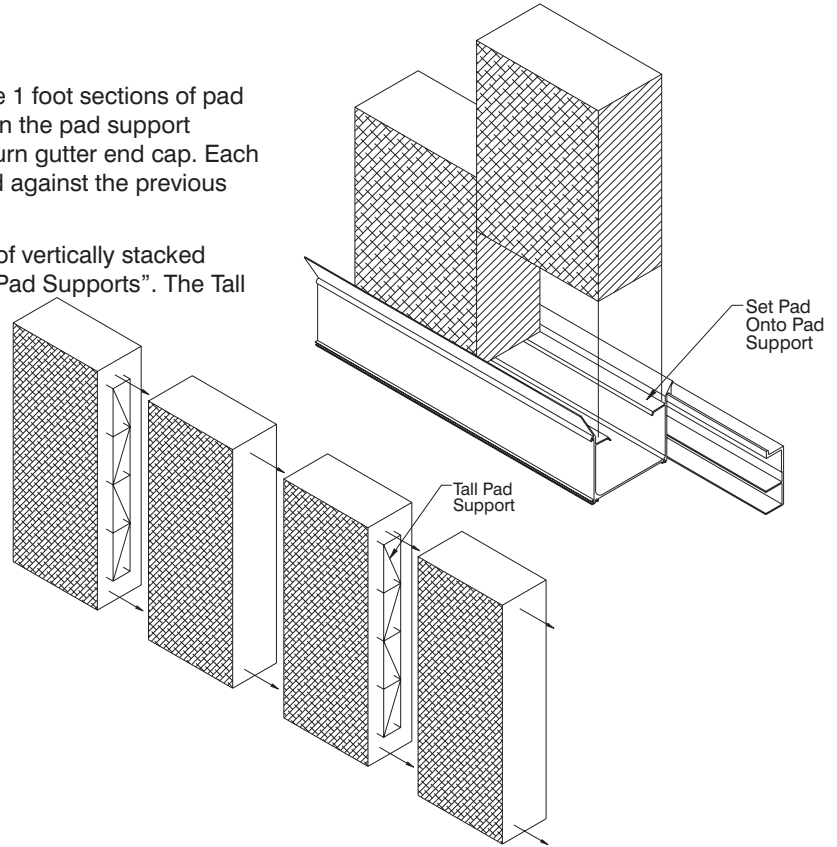

#### H. Install Supply Cap.

1. Beginning at one end of the system, install the sections of supply cap by sliding it down over the top stringer.
2. Install supply cap splice before installing next cap section. Splice is simply slid in until it is centered over the joint.
3. The next cap section is slid over the top of the splice.
4. Repeat steps 2. and 3. until supply cap installation is completed.
5. Notching supply cap. Required for supply entering the center of the system.

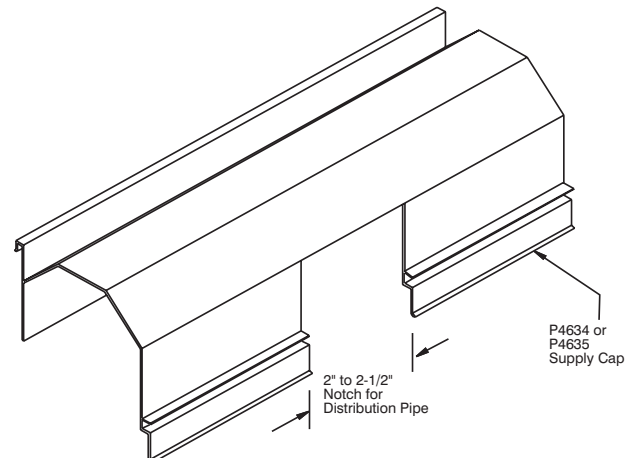
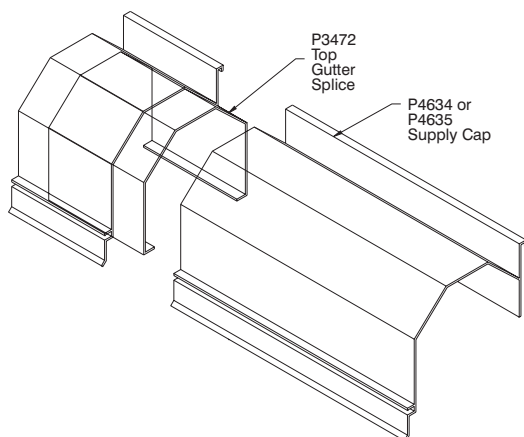

# Installation

## SWAMP THING® (continued)



### I. Installation of End Panels

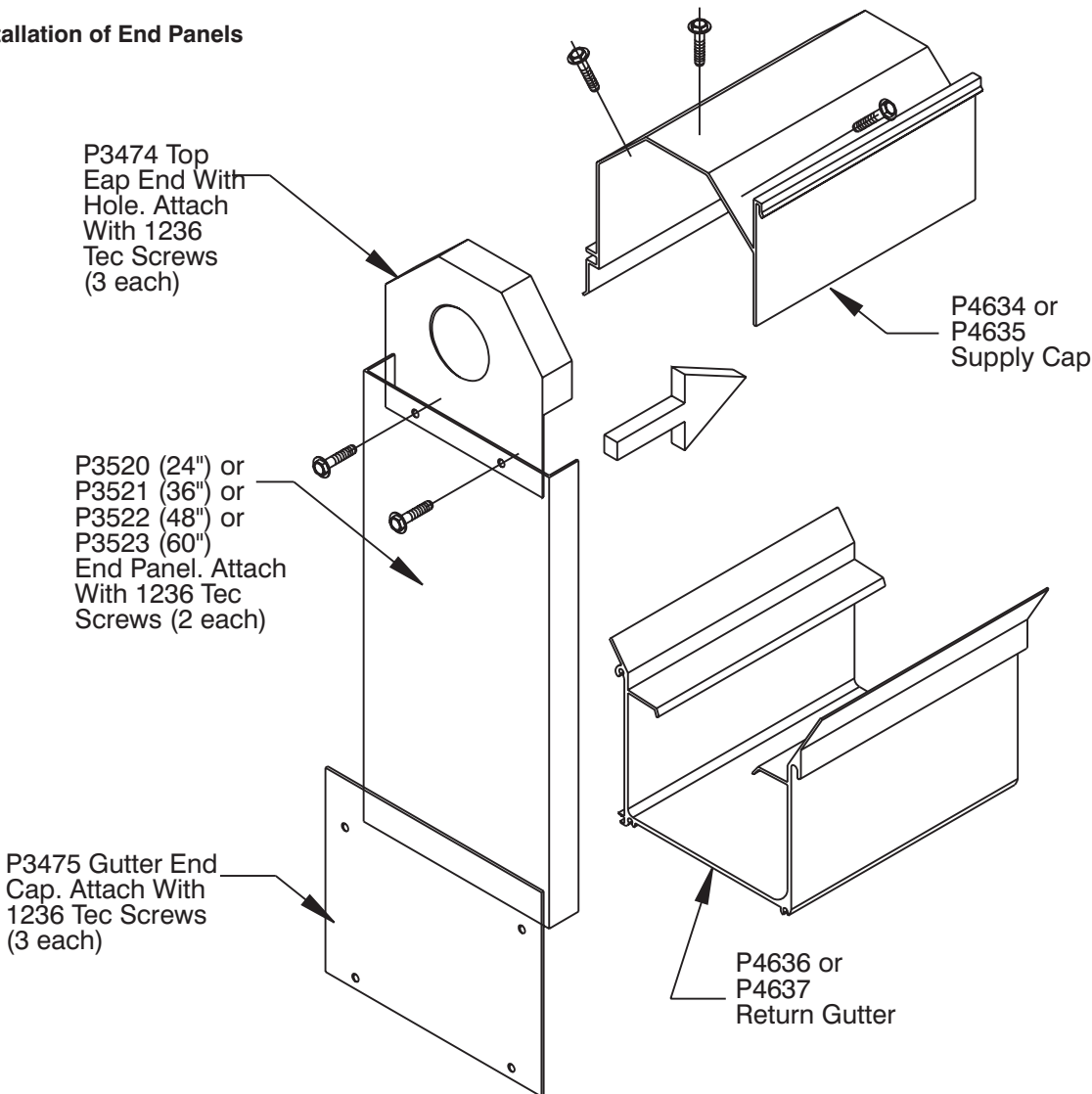

### V. System Start-up and Testing

Before installing the top covers, you may proceed with the start up and testing of the system. If installed, remove top covers.

**Test Water** - Make up water should be tested for pH level and soluble salts. pH must be between 6 and 9 and salt concentrates below 40,000 ppm. See Pad Care.

**Float Valve** - Open the water supply line to the sump. Adjust the float valve so the water shuts off before the water level in the tank reaches the top of the overflow pipe.

**Pump** - Prime the pump (#30 and #60) per instructions received with pump.

**Flush the system** to clean out all accumulated debris as follows:

- Remove plugs from ends of system.
- Open the flow valve. Close clean-out valve.
- Be sure pump is primed prior to operation. Run power to pump and let the system flush out for approx. 5 min.
- Shut the pump off and replace plugs.

**Turn on the pump** and be sure the water is flowing from all holes in the distribution pipe. Clean out any hole that is not spraying water.

**Adjust the flow valve** until the water sprays approximately 12 inches in the air. Replace the pad covers and your system is ready for operation.

**Temperatures** in a greenhouse that are empty will be considerably higher than a greenhouse with plants as the plants assist cooling by their transpiration.





# Installation

## SWAMP THING® (continued)

### Service & Installation

#### VI. System Maintenance

A regular maintenance schedule should be set up to keep your system operating at peak efficiency and to maximize the life of the system.

A visual check should be made whenever you're in the area of the pad:

- Check for dry spots on the pad; see Start-up and Testing.
- Check for algae and scale on pads; see Pad Care.

During the cooling season, when the pad is in operation:

##### **Weekly**

Clean out strainer to prevent possible damage to pump. This may need to be done twice a week.

Clean out sediment plugs at the ends of system (remove plugs and drain into a bucket with system pump off; replace the plugs).

Drain the sump to remove sediment, usually every two to four weeks. In areas with extremely high salt concentrates, this should be done weekly to lower salt concentrates in the sump. (Close flow valve, remove cap plug above pump; connect hose to the nipple and turn on the pump.)

##### **Monthly**

Inspect the complete system:

- Check for leaks and repair;
- Check bleed off connection to insure bleed off is occurring at all times;
- Check the strainer from the downspout in the sump - replace if necessary;

Test water for pH level (make up water and sump water), See Pad Care.

##### **Start and End of Cooling Season**

At the end of each season, drain the pump and piping system to avoid damage caused by rust and impure particles in the water. If the system is outside of the building, you must drain and remove the pump to avoid freeze damage.

To restart the system in the spring, follow the Start up and Testing procedures.

Inspect all parts and pads and replace any damaged or worn parts.

#### VII. Pad Care

Evaporative cooling pads are very durable and long lasting. To maximize the life of your pads and keep the efficiency of the original installation, review the following items and take necessary action to correct any conditions that may be detrimental to the pad.

**pH of recirculating water** (from sump) must be maintained between 6 and 9. (Seven is pure water.) If these limits are exceeded, the stiffening agents in the pad will leach out and destroy the pad. Water containing acids to a degree that the pH is below 6.0 aromatic hydrocarbons, or wetting and dispersing agents, such as phosphates, can be harmful to the pad.

**Hard water** resulting in Calcium Carbonate deposits on the pad is not harmful, but should be kept within limits. The well known Longelier Formula can help to approximate the pH above which the scaling will appear. The help of a good water treatment expert is advisable if any hardness problems are encountered.

**Sodium Chloride** (salt water) concentrate above 50,000 ppm (approx.) will deposit salt on the pad and reduce air flow. Keep salt concentrates below 50,000 ppm in recirculating water and below 40,000 ppm in make-up water.

**Algae** will grow on any surface that is wet and exposed to sunlight. To help prevent algae build up, follow these tips:

- Do not draw make-up water from an open pond. Use well water or chlorinated water from city systems.
- Cover the sump to avoid exposure to sunlight and air borne particles, and to keep animals from drinking it.
- Keep the fans running after the pump is shut off to dry the pads, thus killing the algae spores left on the pad.
- Isolate the water make-up system from any other system that may carry fertilizers which would enhance algae growth.
- If algae persists, use a swimming pool water algicide non-chlorine, chloride (tablet type) in the sump about 1/4 the concentrate suggested for pools.

**Airborne dust and bugs** do not seem to clog the air flow passages. When the system is running this clogging washes away.

When installed **within reach of poultry or livestock it should be guarded**. To guard from poultry birds a 10 x 14 mesh guard approximately 8-12 inches from the pad and to full length of the system should be provided up to approximately 3 feet from birds' feet. The pad should be protected from livestock with a full heavy gauge wire screen approximately 2x2 mesh and placed at least 6 inches from the pad.

**Bleed-Off** - Since the water is continuously evaporating and being replaced by fresh water, the salts and minerals are left behind in the re-circulating water. As these impurities become concentrated, they build up in the pads unless steps are taken to prevent this. To reduce the build-up of deposits and scale, a bleed-off from 1 to 2 percent of the recirculating water is usually required. This is particularly true in areas that have a high mineral content in their water. The required bleed-off is provided by the bleed-off fitting in the plug.